

MATCO'S SELECTIONS

Toll Free: 1-800-221-9090 Office: 412-788-1263 Web: www.matcoinc.com

72 HOUR RUSH AVAILABLE

Why Cathodic Protection?

Why talk about corrosion control? In some segments of the business community the law of the land is "What you don't know, can't hurt you." Underground corrosion of steel pipeline and tanks are often viewed as an unusual condition which occurs as a result of unusual circumstances or environments. The question often is asked, "Will the pipeline corrode?" Rather the question should be, "How long will it be before the pipe starts leaking and replacement becomes necessary?"

In any discussion of underground corrosion of steel pipe or tanks, a number of basic truths should be understood and accepted. These are:

a) Corrosion is an electrochemical process, and starts the moment a steel pipe or tank is installed underground in the soil. Differences in potential at different points along the pipe begin to develop. These potentials generate corrosion currents which leave the pipe to enter the soil at certain selective locations. Corrosion then occurs at

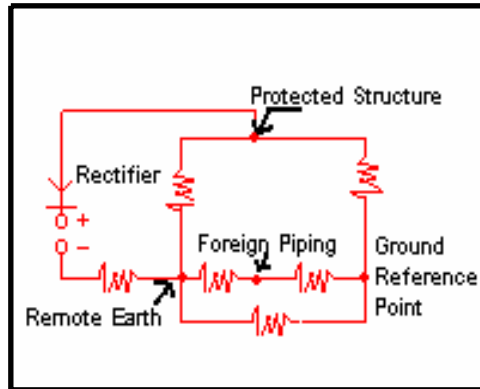

Guess what equivalent circuit this presents?

Contact Dr. Zee at zee@matcoinc.com for the answer.

these selective locations of the pipe structure.

b) Internal or external corrosion of underground facilities in soil or water results in selective and concentrated attacks at coating defects. There is no need to replace a complete piece of pipe or underground tank if corrosion can be controlled at these selective locations.

c) Once leaks start to occur on a pipe or tank, they continue to occur at an exponentially rising rate.

Cathodic protection requires considerable current to protect a bare metal surface of appreciable area. A surface coating reduces the required current by several orders of magnitude.

Since corrosion is a natural phenomenon, we are led to believe that underground steel pipes have a limited life and that they wear out when they get old.

Contrary to popular belief, most corrosion can be easily controlled with a relatively simple technology known as **cathodic protection**.

Cathodic protection can be used in the oil and gas industry to protect pipelines and tanks, as well as the power industry to protect utility poles and underground structures.

Inside...

Why Cathodic Protection? Types Of Cathodic Protection Systems.	Pages 1-2
Removal of Sample for Failure Analysis, MATCO's Chem Lab.	Page 3
Important Points to Remember, Training & Education	Page 4
Info. Needed For Evaluation and MATCO's Capabilities	Page 5
Tid-Bits, Practical Galvanic Series, Contributors, ..	Page 6
Training Seminars And Education.....	Page 7

Types of Cathodic Protection Systems

Two types of systems are commonly used to cathodically protect pipelines: galvanic (magnesium, zinc anode systems) and impressed-current (rectifier) systems.

1. Galvanic Systems -

Magnesium anodes are especially applicable where the soil resistivity and current requirements are low, as in the case of a coated line in low-resistivity soil. The use of magnesium anodes is usually not feasible where the soil resistivity is above about 10,000 ohm-cm, although magnesium ribbon may be used in soils of higher resistivity. Since magnesium is an expensive source of electrical energy, a magnesium anode system usually is not economical where current requirements are high.

2 Rectifier Systems- Rectifiers are especially applicable where electric power is available and current requirements are large or soil resistivity is too high for magnesium. Rectifiers are more flexible than magnesium, since practically any combination of current and voltage ratings is available and the voltage of a rectifier is normally adjustable over a wide range. However, for small current requirements, a rectifier installation is usually more expensive than magnesium.

In cases where either galvanic or rectifiers can be used successfully, the choice is dictated by economics. A cost study is required to determine which type of system is more economically feasible.

Criteria For Protection

Pipe-to-Soil Potential- If a buried pipe line can be maintained at least 0.85 volts negative with respect to a copper sulfate reference electrode in the adjacent soil, it is generally considered adequately protected. This is the criterion normally used to check the level of protection on an existing pipeline.

Potential Change - In the preliminary design of a cathodic protection system based on calculations rather than on field tests, the potential change criterion is frequently used. In this case, a change in potential of at least 0.1 volt in the negative direction with respect to the initial potential may be assumed to indicate adequate protection. The attenuation equations deal with current and voltage changes in the pipeline; for this reason, the voltage change criterion is readily applicable to calculations involving these equations in charts based on them.

Point of Minimum Protection - Since potential varies with distance along a pipe line due to attenuation, the point of minimum protection (least negative potential) must be adequately protected to assure complete protection of a pipe line. With a uniformly coated line protected from a single drain point, the point of minimum protection will be the end most remote from the drain points. With a multiple-drain-point system, points of minimum protection will exist between drain points. One of the main problems encountered in field tests on pipe lines is to determine the locations of

these points of minimum protection. Once these points have been located, it is normally a relatively simple matter to adjust the system (assuming it is adequately designed) to achieve adequate protection at these points and thus complete protection of the line.

Bare and Poorly Coated Lines -

The above discussion is strictly applicable only to uniformly coated pipelines. This is not always the case in practice; bare lines, lines partly wrapped and partly bare, or coated lines with the quality of the coating varying widely from point to point are frequently encountered. In the case of a coated line with variable coating quality, the line will pick up relatively more current from the soil in the areas of poor coating. This will result in larger potential drops in the soil adjacent to the poorly coated sections, and the pipe-to-soil potentials in these areas will be lower (the line will be less negative with respect to adjacent soil) than in nearby areas of good coating. Where lines are partly coated and partly bare, this effect is even more pronounced; the pipe-to-soil potential at a bare area will normally be much lower than that at an adjacent coated area, even though the coated area may be more remote from the drain point.

Where a bare pipe line is buried in soil of uniform resistivity, the potential along the line will vary in the same manner as for a uniformly coated line. However, if a bare line passes through soil where the resistivity varies widely from point to point, current pick-up will be largely concentrated in the areas of low soil resistivity with resulting large potential drops in the soil and low pipe-to-soil potentials in these areas.

(Cont. on pg. 3)

Types of Cathodic Protection Systems (cont.)

Potential Limitations

Coating Deterioration - An excessive potential applied to a coated line has a detrimental effect on the coating; the bond between the coating and the pipe may be destroyed and the coating conductance will increase many times. The rate of coating deterioration increases rapidly as the potential is increased. For this reason, the maximum potential applied to a coated pipe line should not exceed approximately 2.0 to 2.5 volts with reference to copper sulfate, or the potential change should not exceed about 1.5 to 2.0 volts with respect to the initial potential. The lower values should be observed whenever possible.

Maximum Rectifier Spacing - The potential and current at the drain point required to protect a finite line (or the section between minimum points in the case of a multiple-drain-point-system) increase rapidly as the length is increased. Since the potential

change at the drain point should not exceed approximately 1.5 to 2.0 volts, this limits the length of coated line that can be protected from a single drain point and thus determines the maximum spacing between rectifier units in a multiple-drain-point system.

Bare Lines - The maximum voltage that can be applied to a bare line is limited only by economics. An excessive potential will not damage bare steel pipe, but it will result in an excessive current pick-up and inefficient utilization of the applied power.

Sample Removal Techniques For Failure Analysis

The decision to remove a corroded sample specimen for failure analysis root cause determination is an important decision which does not receive enough caution or consideration. Samples selected should be characteristic of the material and contain a representation of the failure or corrosive attack. For example, if a structural member has failed in

service and the cause of failure is to be determined by metallographic examination, the sample should be removed from the particular region of the fracture where it will reveal the maximum amount of information. For comparative purposes, a sample should be taken from a sound section of the unit as well.

There are many different ways that samples can be removed such as; acetylene torch, air arc, saw, trepan, or drill. Some things must be kept in mind upon removal. 1. All cuts made with an acetylene torch should be made at least six inches from the area to be examined. 2. Cuts made by air-arc should be at least four inches away from the area to be examined. If a cut were made closer to the area than stated, the heat generated could alter the microstructure, obscure the type of corrosive attack, or be cumulative to a failure, all of which would render the sample useless. If the available distance for the removal of a sample is less than four inches, saw, trepan or drill out the sample. (cont. on pg. 5)

MATCO'S Corrosion/Coating Laboratory

MATCO's corrosion laboratory specializes in evaluation of pipeline coatings/paints, corrosion analysis for the oil and gas industry, specifically: metals, coatings and paint, corrosivity of gas condensate, rebar corrosion, corrosivity of fuels and oils, and condensed water. We can also determine the corrosivity of fluids in pipeline and tanks as well as soil corrosivity for underground facilities such as pole and lattice tower utility structures.

Laboratory capabilities include: qualitative and quantitative analysis of inorganic and organic coatings by destructive and non-destructive evaluation of pipeline coatings; on-site coating resistance measurements, electrochemical impedance spectroscopy (EIS), SEM/EDS and Infrared Spectroscopy (FTIR); cross section microscopy at low and high magnifications; qualitative and quantitative analysis of volatile sample components using RGA and FTIR; analysis of polymer system nonvolatile components using Pyrolysis GC/MS; evaluation of material thermal properties using Differential Scanning Calorimetry (DSC) and Thermogravimetric Analysis (TGA); physical property evaluations using adhesion, pinhole testing and mechanical impact/abrasive tests; cabinet testing using Impedance Spectroscopy (EIS) combined with salt spray (ASTM B117, ASTM G87), MFG (ASTM B 825, ASTM B 827) and alternate immersion & electrochemical tests (ASTM G 106, ASTM G61, ASTM G82, ASTM G59).

MATCO Associates, Inc. can also provide on-site testing, consultation regarding the application of these techniques in troubleshooting pipeline coating problems, as well as assistance in selection of coatings, proper sampling procedures for corrosion and coating/environmental analysis.

Cathodic Protection - Points To Remember

I. Most important stage of the pipeline life is the installation:

- a) Plan type of coating & tape to be used in advance.
- b) Plan installation of test stations. Proper insulation can isolate CP systems & concentrate protective currents to specific areas.
- c) Eliminate casings wherever possible.
- d) High Voltage (jeep) testing of coating before backfill is necessary.
- e) Backfill with suitable material
- f) CP installed at time of pipe installation may be more cost effective.
- g) CP right-of-way may be easier to acquire with pipeline right-of-way.

II. Improper planning can cause problems:

- a) If galvanic anodes are installed but are not sufficient enough to provide protection, then, impressed current may be needed. Subsequently anodes are going to be wasted.
- b) If rectifier & ground beds are installed but are not sized correctly, more anodes or a larger system may be needed.
- c) Ineffective coating or tape may cause an increase in the current requirement later on.
- d) Improper installation may cause pipeline shutdowns, loss of gas, and waste of time and money.
- e) Improper test station installations mean additional excavation and restoration which can be quite costly.

- f) Casings inhibit CP and should be eliminated wherever possible.
- g) Improper coating installation causes increased current required to protect the pipeline.
- h) Poor backfill causes coating damage and also increases current requirements. If small areas of pipeline have a high current density requirement, this area can go undetected during normal cathodic protection monitoring at test stations. Conduct a close interval survey every five years.

III. Existing pipelines must be evaluated before proper cathodic protection can be installed:

- a) Current requirement tests provide information on type of cathodic protection to be used:
 - 1) Small current - galvanic anodes
 - 2) Large current - impressed current
 - 3) Very large current - distributed impressed current
- b) Soil resistivity tests
 - 1) Define corrosive areas
 - 2) Locate anodes for distributed ground beds

IV. Monitoring is essential to maintain cathodic protection

- a) Annual survey at test stations
- b) Bi-monthly rectifier checks
- c) Close interval survey every 3 to 5 years

V. Common mistakes in designing cathodic protection systems

- a) Using standardized charts when installing distributed anodes without considering variation in soil resistivity.
- b) Assuming an impressed current system is necessary.
- c) Sizing and ordering rectifiers without conducting proper testing.
- d) Assuming a galvanic anode system is necessary.
- e) Assuming company inspectors need not oversee all construction work.
- f) Using inexperienced people for designing and installing a pipeline CP system.

Technical Publications Available

Our articles convey practical engineering information on case histories that will assist readers with their problems. Call us if we can provide you with a technical publication of your interest.

MATCO's Contact Info:

For more information about MATCO Associates, Inc. contact Dr. Zee:

Toll Free: 1-800-221-9090
Phone: (412) 788-1263
Fax: (412)-788-1283
Home Page: www.matcoinc.com
E-mail: info@matcoinc.com

MATCO Associates, Inc.
4640 Campbells Run Rd.
Pittsburgh PA 15205.

Information Needed for Evaluation of Pipeline Corrosion and Cathodic Protection

Proper Technique In Removal Of Sample For Failure Analysis (cont.)

Prime importance must be placed on removing the sample without any physical damage to the area to be examined. Beating on the sample with a hammer may destroy surface condition information. Physical abuse of the sample may also destroy the corrosion product. Analysis of the corrosion products is important in determining the corrosive agent.

Normally, the analyst will not physically cut and remove the sample from the piece of equipment. Therefore, the specific sample area must be marked or a representative of the analyst should outline the "exact" area to be removed from the equipment. By the analyst being present when the sample is removed, improper removal procedures are less likely to occur.

A photograph of the piece of equipment including the sample to be removed should be taken. This will suffice to show the relationship of the examined area to the remainder of the piece of equipment. If more than one sample is to be taken, proper designation of the samples and their location relative to the piece of equipment should be noted. The dimensions of the sample should be recorded as well as the date the failure occurred. To perform a complete metallurgical examination of a failure, samples from the failure, adjacent to the failure, and away from the failure are necessary.

Corrosion can and does have a detrimental impact on the environment, resulting in increased or unnecessary repair costs, and can effect the structural integrity of pipelines. A professionally designed and maintained Cathodic Protection System can extend the life of your facility.

1. Piping system specifications and practices
 - (a) Route maps and atlas sheets
 - (b) Pipe, fittings and other appurtenances
 - (c) Coating characteristics, specific resistance, efficiency
 - (d) Casings
 - (e) Test stations
 - (f) Electrical insulating devices
 - (g) Electrical bonds
 - (h) Aerial, ridge, and underwater crossings
2. Piping system site conditions
 - (a) Existing and proposed cathodic protection systems
 - (b) Possible interference sources
 - (c) Special environmental conditions
 - (d) Neighboring buried metallic structures (locations, ownership, and corrosion control practices)
 - (e) Power availability
 - (f) Structure accessibility
 - (g) Feasibility of electrical isolation from foreign structures

Non routine analysis requests are welcomed. MATCO can also provide on site consultation regarding the application of these techniques in trouble-shooting gas-pipeline problems, as well as offer assistance in proper sampling procedures for corrosion and environmental analysis.

MATCO's Capabilities

- Cathodic protection
- Internal and external corrosion monitoring
- Interpret federal and state regulations on corrosion control
- CP trouble shooting
- Computerized close interval survey
- Materials selection
- Failure analysis
- Metallography
- Electron microscopy (SEM)
- Mechanical testing
- Inspection services
- Coating failure analysis
- Weld inspection
- Laboratory analysis
- On-site investigation

Why Select MATCO Associates?

MATCO Associates, Inc. is an independent consulting engineering firm specializing in cathodic protection, materials testing, selection & design and corrosion investigations. Headquartered in Pittsburgh, Pennsylvania, MATCO Associates, Inc. is staffed by NACE certified engineers and Ph.D.'s. We will complete work on time and within budget. Your business is **very important** to us and we urge you to contact our offices if we can be of service:

To Contact MATCO:
Toll Free: 1-800-221-9090
e-mail: info@matcoinc.com
Headquarters: Pittsburgh, PA
Satellites: Dubai, UAE
Miami, FL
Oahu, HI

72 Hour Rush Service

PRACTICAL GALVANIC SERIES

Typical potential normally observed in neutral soils and water, measured with respect to copper sulfate reference electrode is shown in the following table. Galvanic corrosion results from the electrical coupling of dissimilar metals in an electrolyte such as water or soil.

METAL	VOLTS
Commercially pure magnesium	-1.75
Magnesium alloy (6%Al, 3% Zn, 0.15%Mn)	-1.6
Zinc	-1.1
Aluminum alloy (5% zinc)	-1.05
Commercially pure aluminum	-0.8
Mild steel (rusted)	-0.5 to-0.8
Cast iron (not graphitized)	-0.5
Lead	-0.5
Mild steel in concrete	-0.2
Copper, brass, bronze	-0.2
High silicon cast iron	-0.2
Mill scale on steel	-0.2
Carbon, graphite, coke	+0.3

Meet MATCO Senior Staff:

Dr. Zee - Ph.D. in materials science, with over 65 publications in areas of materials performance, coatings and cathodic protection. He holds four certifications from National Associations of Corrosion Engineers (NACE). He also holds twenty five patents. He is in charge of corrosion engineering investigations at Matco Associates Inc.

Walter Gretz - A professional engineer with thirty years of experience in the steel industry. He is vice president of MATCO Associates, Inc. and has conducted more than 4000 metallurgical failure analyses.

Ed Larkin: Vice President of Materials Engineering

Geoff Rhodes, Technical Director and Manager of Corrosion and Cathodic Protection Division.

Debra Riley, Administrator & Project Coordinator, NACE Certified in Corrosion, Level 1

George Bayer, Ph.D., Manager of Paint/Coatings Div.

Don Gibbon, Ph.D., Micro-characterization Specialist

Joe Turek, Manager of Metallurgical Division

Resistivity Measurements

The following information can be derived from soil resistivity measurements:

1. Areas where corrosion can be anticipated because of variations in soil resistance.
2. Determination of optimum locations of corrosion control equipment.
3. Amount of cathodic protection current material necessary for given life expectancy.

MATCO Develops Software for Cathodic Protection Design

MATCO is developing a practical expert system software for use in cathodic protection design of underground pipelines. This software is the only one of its kind that considers the variation in soil resistivity in the design of cathodic protection systems.

ANTICIPATED CORROSION ACTIVITY FOR STEEL EXPOSED TO SOILS OF VARYING	
Resistivity (ohm-cm)	Corrosion Activity
0-749	Extremely Corrosive
749-2599	Corrosive
2600-9999	Moderately Corrosive
>10,000	Progressively Less Corrosive

MATCO'S SELECTIONS

Toll Free: 1-800-221-9090 Office: 412-788-1263 Web: www.matcoinc.com

TRAINING AND EDUCATION

To promote better understanding of materials performance in different types of environments, MATCO Associates, Inc. offers many different training and educational seminars. Seminars can be arranged to be held onsite or at our location for a nominal fee which includes certifications. The instructors include professional engineers, material scientists, and coating/cathodic protection specialists.

During 2000-2005 MATCO has provided many seminars and short courses for clients and associations, such as: Appalachian Underground Corrosion Short Course (West Virginia); IBM facilities (New York); Marco Energy Systems (West Virginia); National Association of Corrosion Engineers (NACE, Pittsburgh Chapter); and ASM International (Wisconsin and Pittsburgh). Currently, we are organizing two seminars one on Corrosion and Failure Analysis and one on Cathodic Protection/Coating and Pipe Line Corrosion. Those interested in either of these seminars or future seminars should contact Dr. Zee at 1-800-221-9090.



inside...

Why Cathodic Protection? Types Of Cathodic Protection Systems.	Pages 1-2
Removal of Sample For Failure Analysis, MATCO's Chem. Lab.	Pages 3
Imp. Points to Remember, Training And Education, Address	Pages 4
Info. Needed For Evaluation..., MATCO's Capabilities	Pages 5
Tid-Bits, Practical Galvanic Series, Contributors, Sports	Pages 6